

型号

PQ-3230

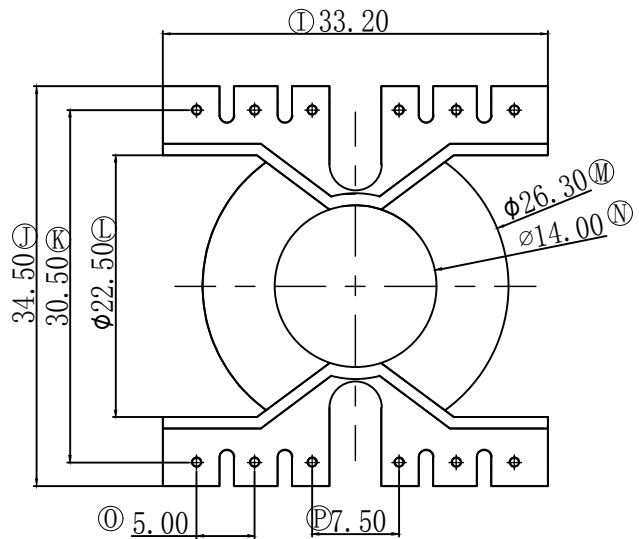
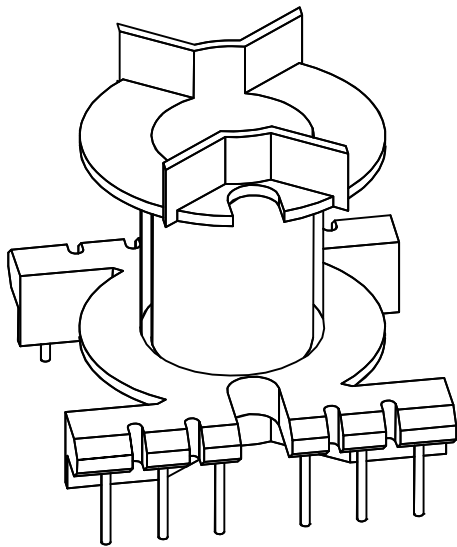
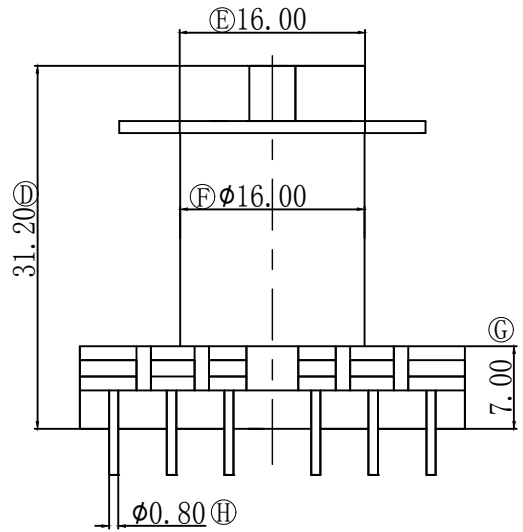
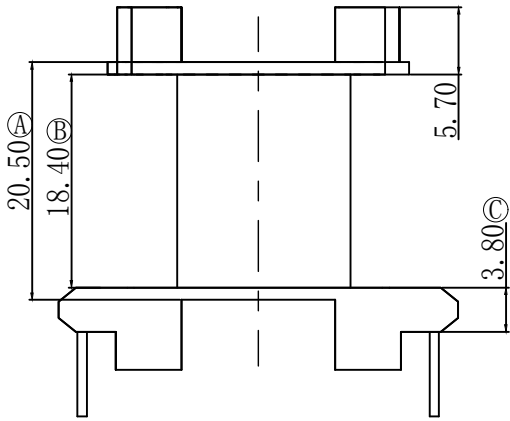

深圳市金辉鼎电子科技有限公司

地址: 深圳市公明街道将石社区油麻岗港深高新科技园
0755-27658768 传真 0755-27646486

ANGLE:
+/-1°

UNIT:
mm

SCALE:
1/1

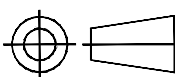

MODEL NAME:
PQ-32 (6+6PIN)

UL RECOGNITION:
UL 94V-0

PIN TEN LOAD:
1.0 Kg MIN

DATE:
2008/03/01

BOBBIN MATERIAL:
PHENOLIC

PIN MATERIAL:
CP WIRE

DRAWING NO:
REV:
1.0

DRAFTER 刘金

CHECKER 张威超

TOLERANCES

0<L≤4	±0.1
4<L≤16	±0.2
16<L≤50	±0.3
PIN PITCH	±0.20