

型号

PQ-3205

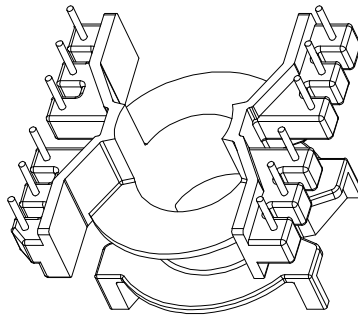
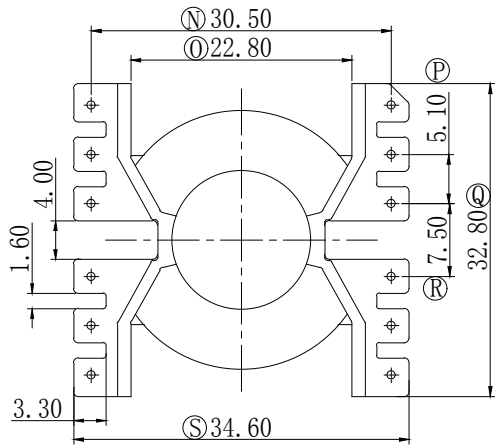
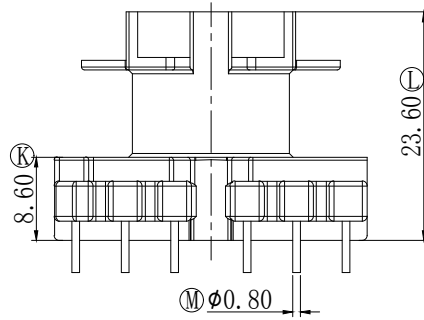
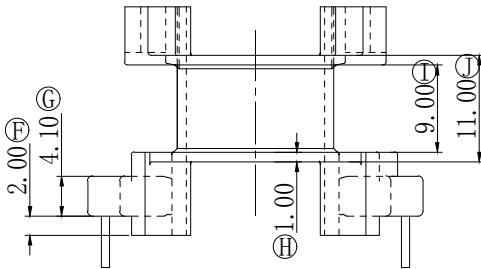
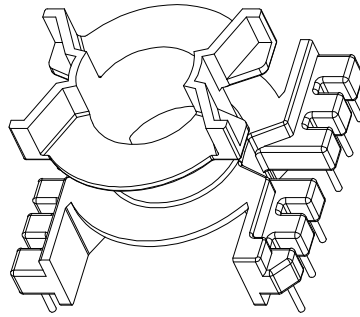
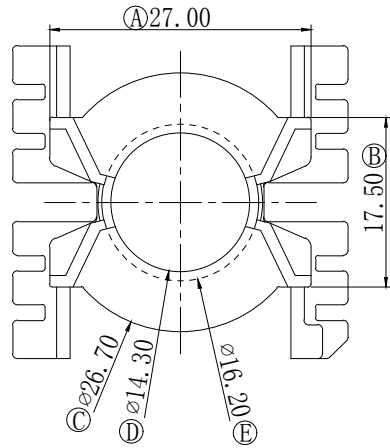

深圳市金辉鼎电子科技有限公司

地址: 深圳市公明街道将石社区油麻岗19号

电话 0755-27658768 传真 0755-27646486

ANGLE:  
+/-1°

UNIT:  
mm

SCALE:  
1/1

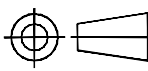

MODEL NAME:  
PQ-32 (6+6PIN)

UL RECOGNITION:  
UL 94V-0

PIN TEN LOAD:  
1.0 Kg MIN

DATE:  
2017/10/13

BOBBIN MATERIAL:  
PHENOLIC

PIN MATERIAL:  
CP WIRE

DRAWING NO:

REV:  
1.0

DRAFTER

张威超

CHECKER

张威超

TOLERANCES

0<L≤4	±0.1
4<L≤16	±0.2
16<L≤50	±0.3
PIN PITCH	±0.20