

型号

PQ-2608

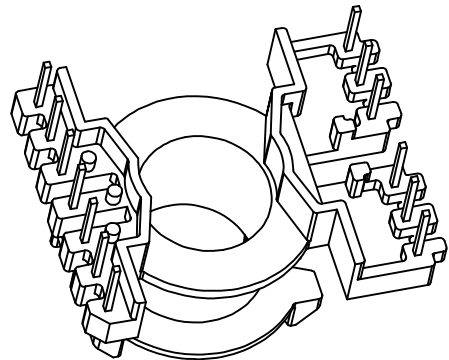
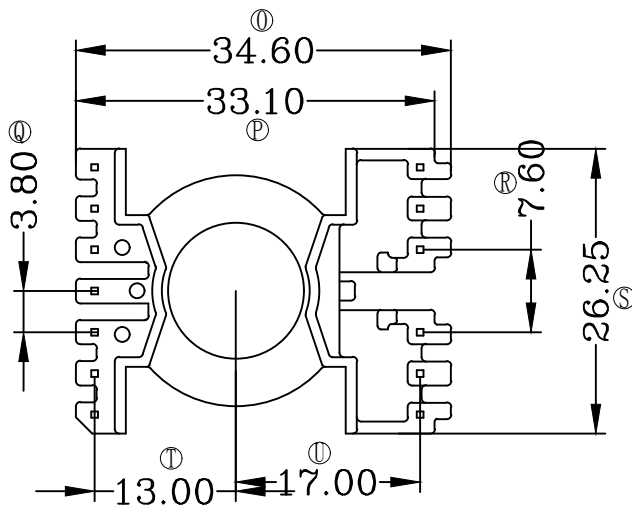
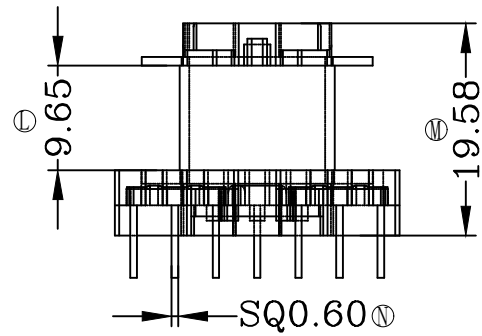
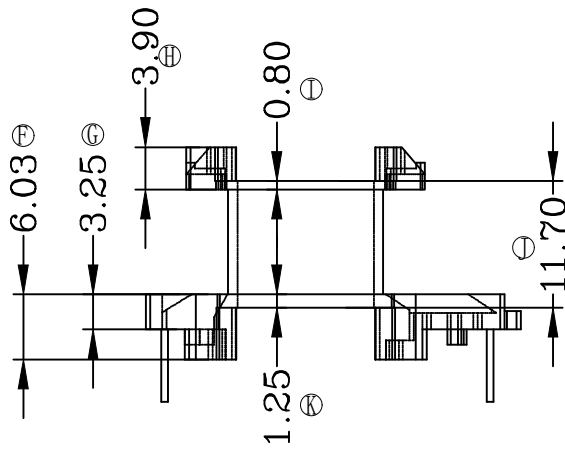
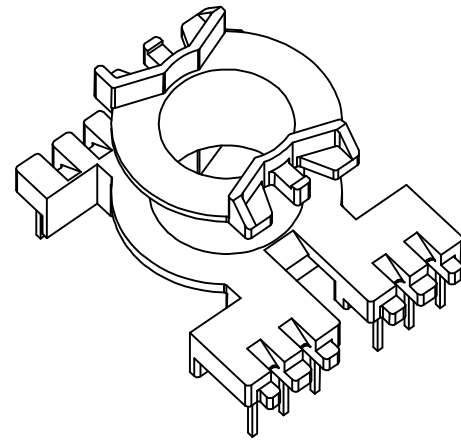
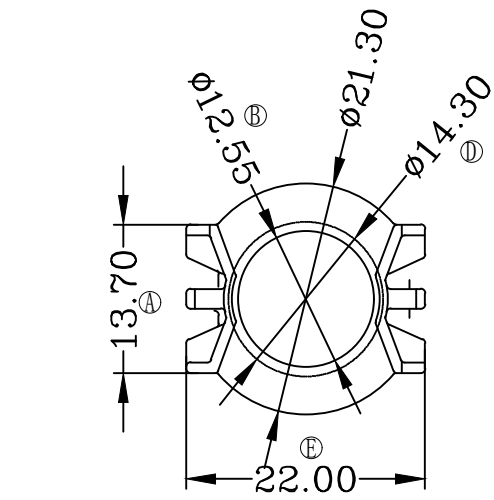

深圳市金辉鼎电子科技有限公司

地址: 深圳市公明街道李松荫社区荣泰佳工业园3栋

电话 0755-27658768 传真 0755-27646486

ANGLE:
+/-1°

MODEL NAME:
PQ26 (7+6) P

UNIT:
mm

UL RECOGNITION:
UL 94V-0

BOBBIN MATERIAL:
T375HF PHENOLIC

DRAFTER

刘金

TOLERANCES

0L4 ±0.1
4L16 ±0.2
16L50 ±0.3
PIN PITCH ±0.20

SCALE:
1/1

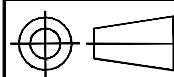

PIN TEN LOAD:
1.0 Kg MIN

PIN MATERIAL:
CP WIRE

CHECKER

张威超

DATE:
2021/12/16

DRAWING NO:

REV:
1.0